

# MC CLAMP

*Mechanical clamp*

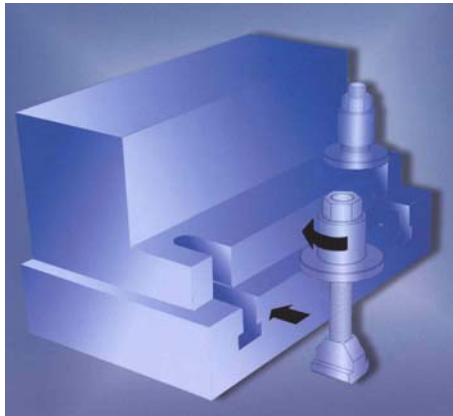

- Quick die clamping
- Geared mechanisms for fast and vibrate-proof clamping
- 1 nut revolution = 4 - 5,5 mm adjustment
- All in one complete unit with forged bolt
- Customized height
- Stroke 15-35mm, depending on type
- Easy to store nearby in bracket (MC-H option)
- Safe handling



*MC-Clamp in clamped position*

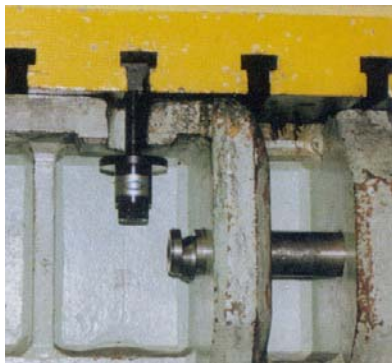

*MC-Clamp, for upper die, in un-clamped position*



*MC-Clamp for lower die, in clamped position*

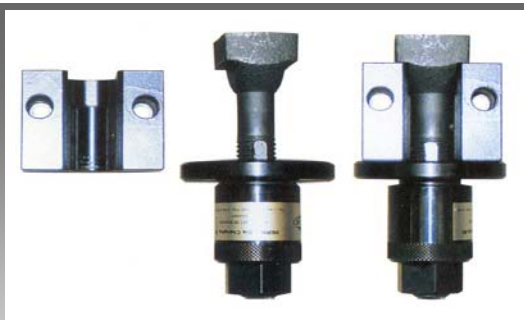

*MC-H bracket for MC-Clamp*



*Ratchet wrench for MC-Clamp*

- H10-46 635mm / 2,30 kg*
- H8-36 500mm / 1,16 kg*
- H6-30 400mm / 0,75 kg*
- H4-24 305mm / 0,50 kg*

# MC CLAMP

Mechanical clamp

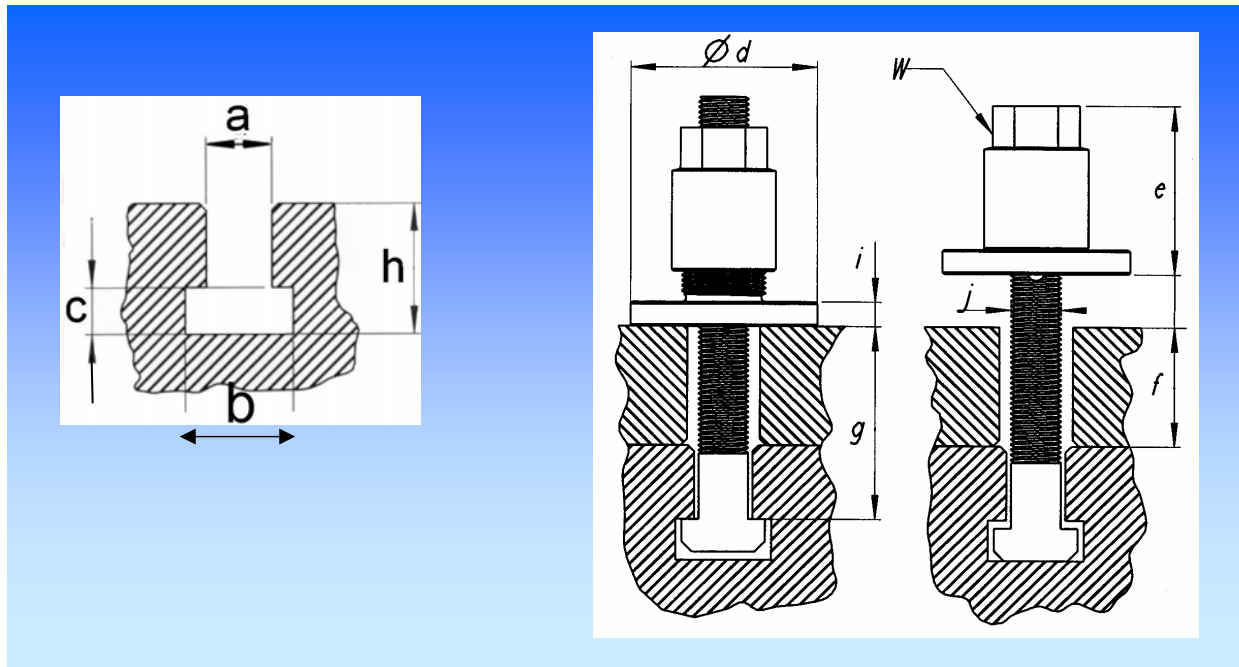

Specify							
Type	a	b	c	h	f min	f max	amount

Type	Clamping force kN	Tightening torque Nm	Stroke	d	e	f	g	i	j	Weight Kg	W Socket mm	Wrench Art. No	Bracket (storage)
MC-4-18	40	120	15	40	51	Customized		8	16	1	24	H4-24	MC4-H
MC-6-22	60	180	20	50	65			10	20	1,5	30	H6-30	MC6-H
MC-8-28	80	240	30	90	82			12	24	2	36	H8-36	MC8-H
MC-10-36	100	300	35	90	85			12	30	2,5	46	H10-46	MC10-H



Binar Olofström AB  
 Västra Storgatan 20  
 SE-293 38 OLOFSTRÖM  
 Tel: +46 (0)454 323055  
 Fax: +46 (0)454 322044

e-mail: info@binar.se  
 Website: www.binar.se