



OLOFSTRÖM

UNIFEEDER



PRESS AUTOMATION

LOAD TABLE

- **Simple and solid construction.**
- **Both single and double panels can be handled.**
- **Up to 16 automatic adjustable axis.**
- **Many year's experience from industrial controllers and press automation contributes to user friendliness and high productivity.**

Functional Principle

The Load Table is a device for locate panel before loading it into the Press.

Handling Capability: Singel + DNA blanks		
Feed direction	<u>Singel</u> min 100 mm max 2500 mm.	<u>Double</u> min 100 mm max 2500 mm.
Width	min 100 mm. max 4500 mm	min 100 mm. max 2200 mm/panel
Weight. (panel). Speed	max 60 kg. ca 17 stroke/min.	
Weight:	800 kg	

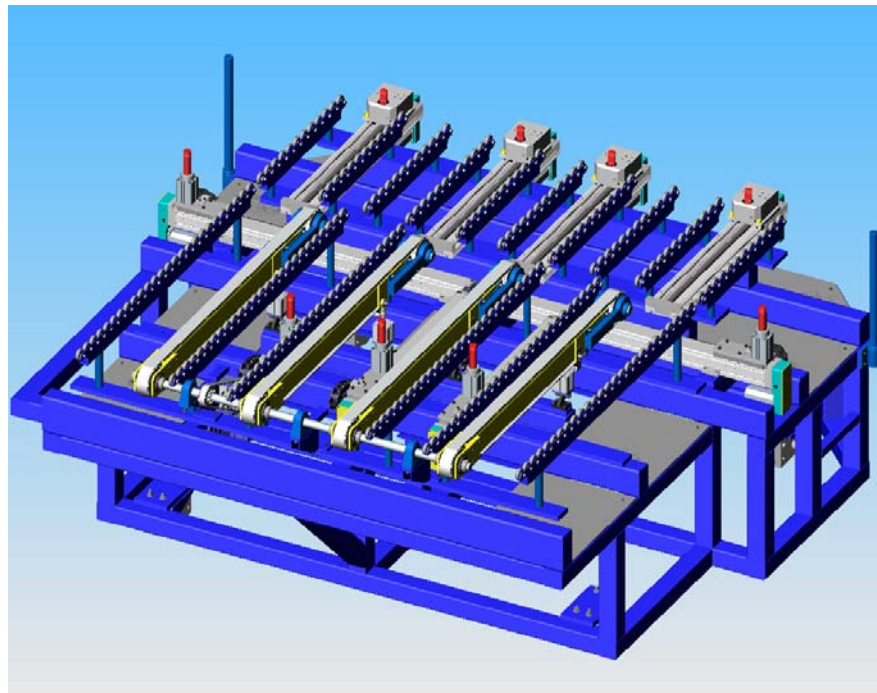

Data for speed is stored in the control system.

Edition 1.11 eng